



US 20050078164A1

(19) **United States**

(12) **Patent Application Publication** (10) **Pub. No.: US 2005/0078164 A1**

Kwon et al.

(43) **Pub. Date: Apr. 14, 2005**

(54) **BARCODE MARKING METHOD AND APPARATUS FOR ELECTRO-LUMINESCENCE DISPLAY DEVICE**

(30) **Foreign Application Priority Data**

Oct. 13, 2003 (KR)..... P2003-71075

Publication Classification

(75) Inventors: **Seung Ho Kwon**, Seoul (KR); **Yoon Heung Tak**, Kyongsangbuk-do (KR)

(51) **Int. Cl.⁷** **B41J 2/01**

(52) **U.S. Cl.** **347/107**

Correspondence Address:
**BIRCH STEWART KOLASCH & BIRCH
PO BOX 747
FALLS CHURCH, VA 22040-0747 (US)**

(57) **ABSTRACT**

The invention relates to a barcode marking method and apparatus for an electro-luminescence display device. According to the barcode marking method and apparatus for an electro-luminescence display device of the present invention includes, an information barcode is marked on the electro-luminescence display devices by using the ink jetted from the ink-jet head while moving at least any one of the stage and the ink-jet head.

(73) Assignee: **LG Electronic Inc.**

(21) Appl. No.: **10/960,968**

(22) Filed: **Oct. 12, 2004**

10

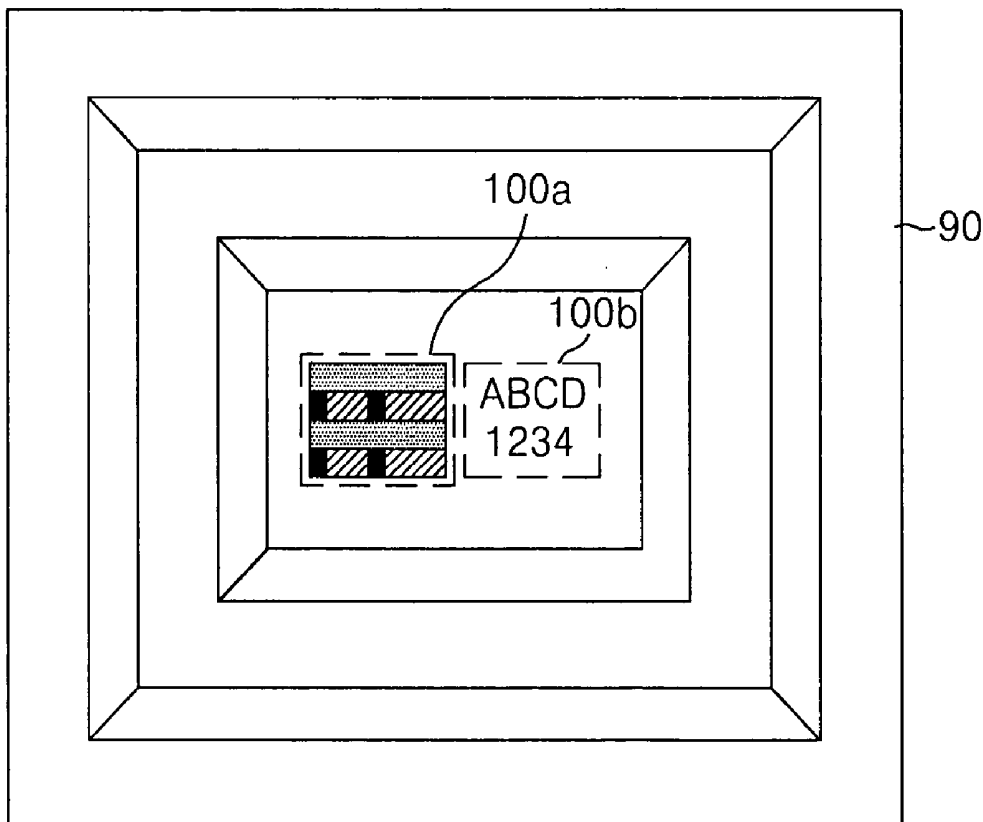

FIG. 1

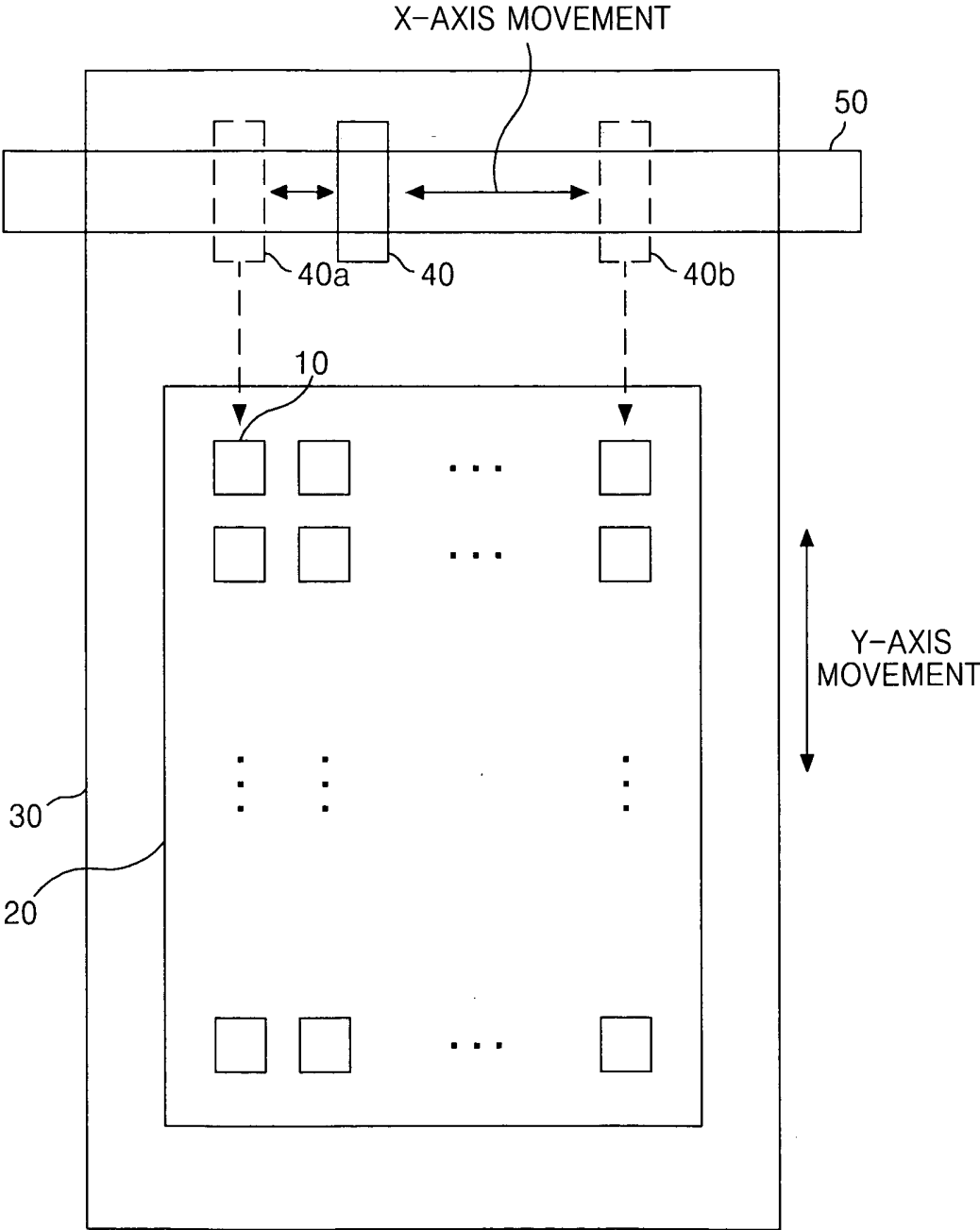

FIG. 2

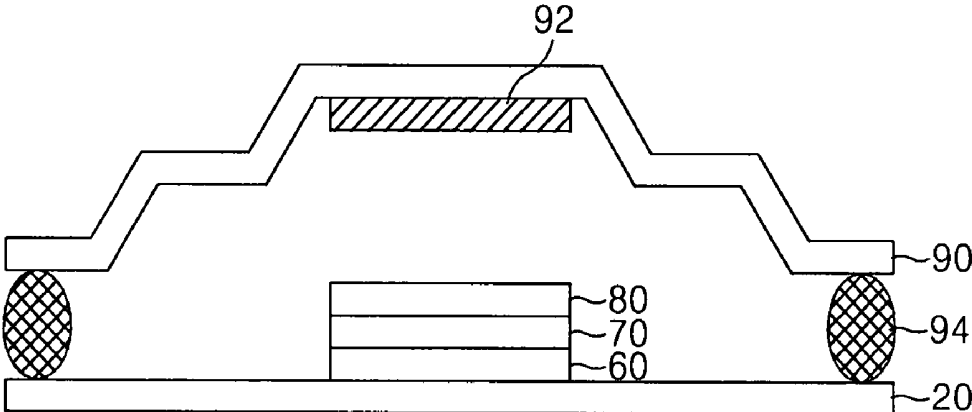

FIG. 3

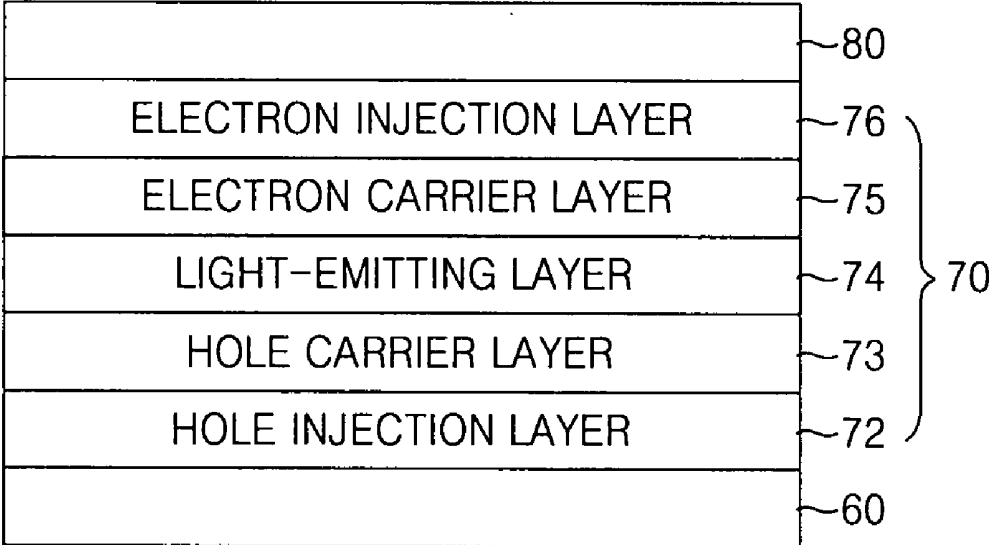

FIG. 4

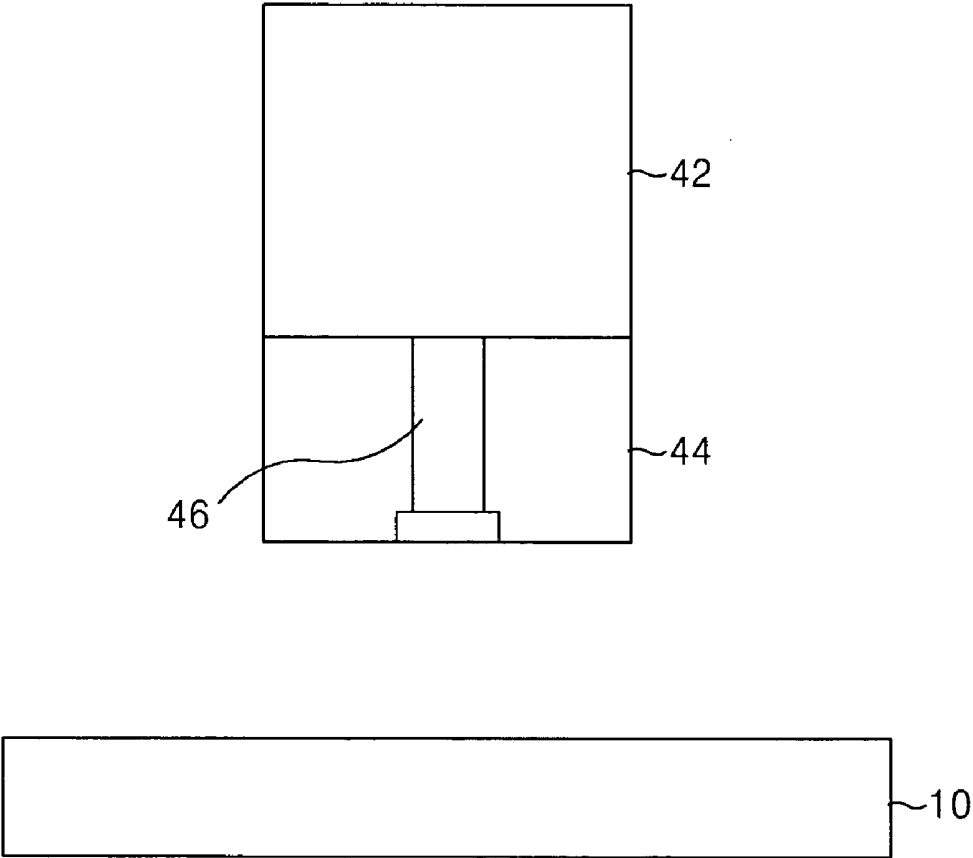

FIG. 5A

10

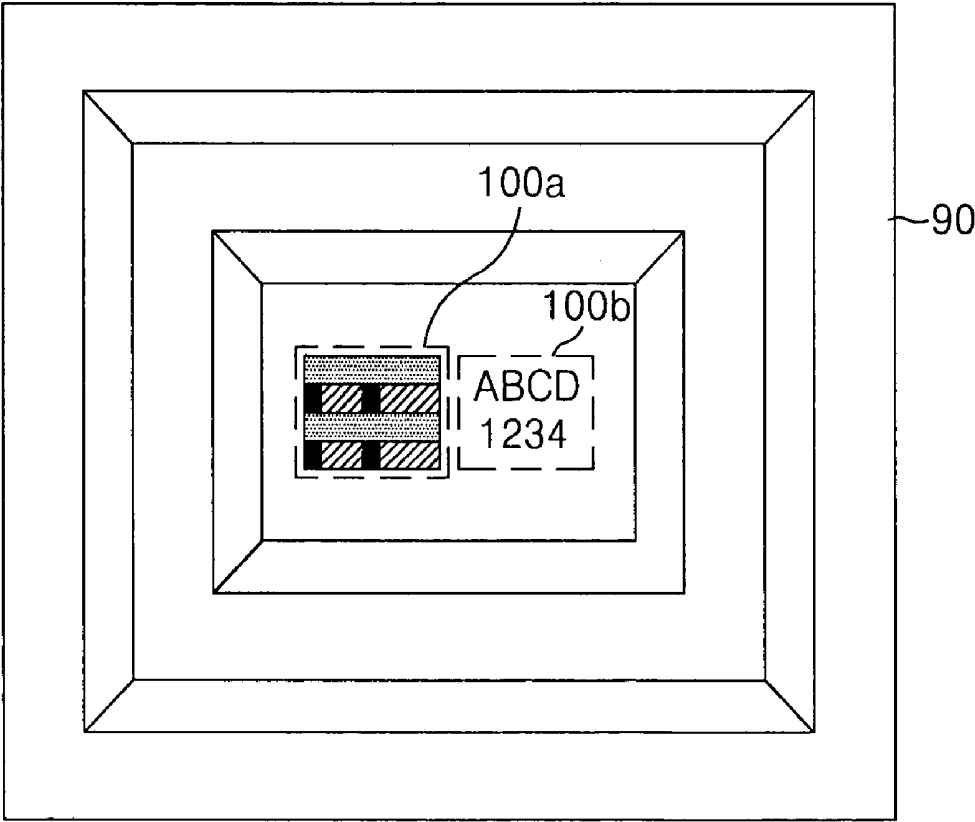
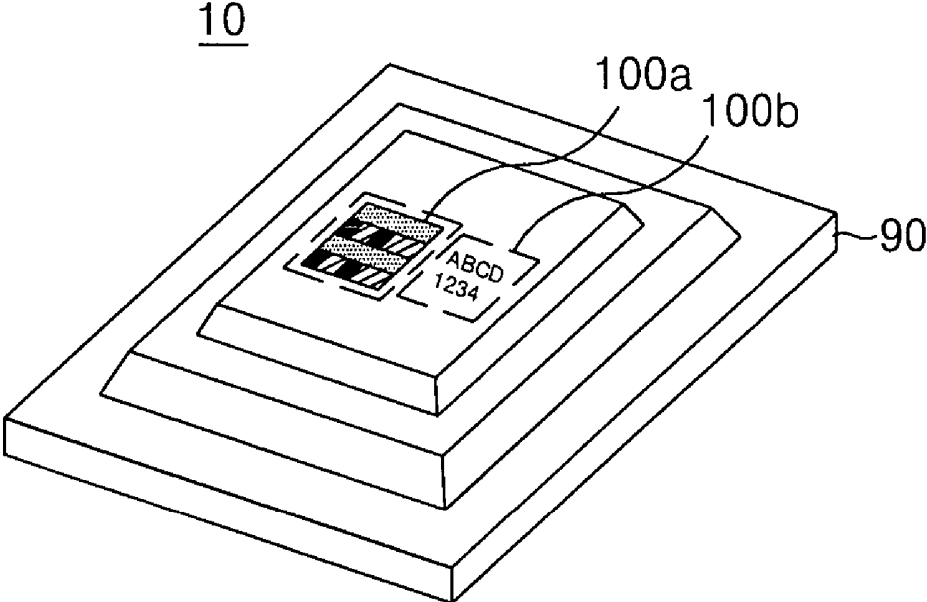

FIG. 5B



BARCODE MARKING METHOD AND APPARATUS FOR ELECTRO-LUMINESCENCE DISPLAY DEVICE

[0001] This application claims the benefit of Korean Patent Application No. P2003-71075 filed in Korea on Oct. 13, 2003, which is hereby incorporated by reference.

BACKGROUND OF THE INVENTION

[0002] 1. Field of the Invention

[0003] This invention relates to a barcode marking method for an electro-luminescence display device, and more particularly, to a barcode marking method and apparatus for an electro-luminescence display device capable of improving a production yield.

[0004] 2. Description of the Related Art

[0005] Recently, there have been highlighted various flat panel display devices reduced in weight and bulk that is capable of eliminating disadvantages of a cathode ray tube (CRT). Such flat panel display devices include a liquid crystal display (LCD) device, a field emission display (FED) device, a plasma display panel (PDP), an electro-luminescence (EL) display and the like.

[0006] Among these, the EL display device is a spontaneous light-emitting device capable of light-emitting a phosphorous material by a re-combination of electrons with holes. The EL display device is generally classified into an inorganic EL device using an inorganic compound as the phosphorous material and an organic EL device using an organic compound as the phosphorous material. The EL display device has many advantages of a low voltage driving, a self-luminescence, a thin-thickness, a wide viewing angle, a fast response speed and a high contrast, etc. such that it can be highlighted into a post-generation display device.

[0007] Meanwhile, it is common that the EL display device has not any marks thereon, e.g., on its sectional surface, but it is current trend to mark an information barcode on the EL display device for the identification. According to the international organization for standardization ISO for, it is required that the information barcode should be marked on the sectional surface of the EL display device. Accordingly, in order to mark the information barcode on the sectional surface of the EL display device, there are employed several methods including a manual labor using a marking pen, a method of etching a substrate of the EL display device by a laser to directly mark the information barcode inside the EL display device, and a method of sticking a sticker having a printed information barcode on a rear surface of the EL display device.

[0008] However, the manual labor using the marking pen is applicable to a large-sized display device, but it is difficult to applicable to such a small-sized display device as an EL display device. Also, since the manual labor is manually performed, there is a problem that a production yield is deteriorated. The method of etching the substrate of the EL display device by the laser has a disadvantage that a repair of the EL display device is impossible when an information barcode is wrongly marked, or when a badness is occurred during the marking process of the information barcode. Further, the method of sticking the sticker having the printed

information barcode on the rear surface of the EL display device has a disadvantage that the sticker is easily detached from the EL display device and the repair is impossible as the laser method.

SUMMARY OF THE INVENTION

[0009] Accordingly, it is an object of the present invention to provide a barcode marking method and apparatus for an electro-luminescence display device capable of improving a production yield.

[0010] In order to achieve these and other objects of the invention, a barcode marking method for an electro-luminescence display device, using an ink-jet head and a stage which are installed movable respectively, includes: disposing a substrate having a plurality of electro-luminescence display devices on the stage; and marking an information barcode on the electro-luminescence display devices by using the ink jetted from the ink-jet head while moving at least any one of the stage and the ink-jet head.

[0011] The stage is moved along any one of X-axis direction and Y-axis direction.

[0012] The ink-jet head is moved along any one of X-axis direction and Y-axis direction, which are crossed from a moving direction of the stage.

[0013] The information barcode includes: a date information representing the time when the electro-luminescence display device is made; and a property information representing the property of each the electro-luminescence display device.

[0014] The information barcode includes: a first barcode; and a second barcode different shape from the first barcode.

[0015] The first barcode includes a two-dimension (2D) letter shape, and the second barcode includes a text.

[0016] The first and the second barcodes are marked together with on the same electro-luminescence display device.

[0017] Each electro-luminescence display device includes an organic light-emitting layer and a packaging plate for encapsulating the organic light-emitting layer.

[0018] The first and the second barcodes are marked on the packaging plate.

[0019] A barcode marking apparatus for an electro-luminescence display device, includes: an ink-jet head which is installed to be movable and can jet the ink; and a stage, installed to be movable toward a moving direction crossing a moving direction of the ink-jet head, for disposing a substrate having a plurality of electro-luminescence display devices thereon, wherein an information barcode is marked on the electro-luminescence display devices by using the ink jetted from the ink-jet head while moving at least any one of the stage and the ink-jet head.

[0020] A barcode marking apparatus for an electro-luminescence display device, includes: a stage, installed to be movable toward a Y-axis direction, for being disposed a mother glass in which a column of a plurality of electro-luminescence display devices is formed along a X-axis direction and a row of a plurality of electro-luminescence display device is formed along the Y-axis direction; and an

ink-jet head, installed to be movable toward the X-axis direction and jetting the ink, for marking together with at least two or more information on each the electro-luminescence display device.

[0021] At least the two or more information are marked in a text shape together with a two-dimension (2D) letter shape on each the electro-luminescence display device.

[0022] At least the two or more information are marked on the packaging plate.

BRIEF DESCRIPTION OF THE DRAWINGS

[0023] These and other objects of the invention will be apparent from the following detailed description of the embodiments of the present invention with reference to the accompanying drawings, in which:

[0024] FIG. 1 is a block diagram representing a barcode marking device for an electro-luminescence display device according to an embodiment of the present invention;

[0025] FIG. 2 is a sectional view fully illustrating the electro-luminescence display device shown in FIG. 1;

[0026] FIG. 3 is block diagram illustrating an organic light-emitting layer in the electro-luminescence display device shown in FIG. 2;

[0027] FIG. 4 shows a detailed ink-jet marker in the barcode marking device for the electro-luminescence display device shown in FIG. 1; and

[0028] FIGS. 5A to 5B illustrate an information barcode marked in the electro-luminescence display device by using the barcode marking device for the electro-luminescence display device shown in FIG. 1.

DETAILED DESCRIPTION OF THE PREFERRED EMBODIMENT

[0029] Reference will now be made in detail to the preferred embodiments of the present invention, examples of which are illustrated in the accompanying drawings.

[0030] Hereinafter, the preferred embodiments of the present invention will be described in detail with reference to FIGS. 1 to 5B.

[0031] FIG. 1 is a block diagram representing a barcode marking device for an electro-luminescence display device according to an embodiment of the present invention.

[0032] Referring to FIG. 1, the barcode marking device for an electro-luminescence display device according to the embodiment of the present invention includes: a stage 30; a substrate 20 mounted on the stage 30; a plurality of EL display devices 10 formed on the substrate 20; an ink-jet marker for marking an information barcode in the EL display devices 10; and an ink-jet driver 50 for supporting and driving the ink-jet marker 40.

[0033] The EL display devices 10 includes an anode electrode 60 with a transparent electrode pattern on the substrate 20 and an organic light-emitting layer 70 stacked on the anode electrode 60, as shown in FIG. 2. A cathode electrode 80 as a metal electrode is formed on the organic light-emitting layer 70. Also, since the organic light-emitting layer 70 is apt to be damaged by moisture and oxygen in the atmosphere, a packaging plate 90 is formed in order to

protect the organic light-emitting layer 70. The packaging plate 90 is made of material such as glass, plastic or canister. The packaging plate 90 includes a first horizontal surface on which a sealant 94 is applied, a second horizontal surface having a designated step height from the first horizontal surface; and a third horizontal surface having a designated step height from the second horizontal surface.

[0034] A getter 92 is attached on a bottom surface of the third horizontal surface in the packaging plate 90 to absorb the moisture and the oxygen.

[0035] The getter 92 includes a powder getter such as barium oxide (BaO) or calcium oxide (CaO) enveloped by a polyethylene system package. A net is adhered on one side of the packaging paper in order to make the oxygen and the moisture to go in and out.

[0036] Herein, the organic light-emitting layer 70 stacked between the anode electrode 60 and the cathode electrode 80 includes an electron injection layer 76, an electron carrier layer 75, a light-emitting layer 74, a hole carrier layer 73, and a hole injection layer 72, as shown in FIG. 3.

[0037] When a voltage is applied between the anode electrode 60 and the cathode electrode 80, electrons produced from the cathode electrode 80 are moved, via the electron injection layer 76 and the electron carrier layer 75, into the light-emitting layer 74. Moreover, holes produced from the anode electrode 60 are moved, via the hole injection layer 72 and the hole carrier layer 73, into the light-emitting layer 74. Thus, the electrons and the holes supplied from the electron carrier layer 75 and the hole carrier layer 73, respectively, are collided at the light-emitting layer 74, so that they are recombined to thereby generate light. This light is emitted, via the anode electrode 60 of the transparent electrode, into the exterior to thereby represent a picture. Since a light-emitting brightness of the organic EL device is in proportion to a supplied current rather than in proportion to a voltage applied to both end of the EL device, the anode electrode is commonly connected to a constant current source.

[0038] The stage 30 is supported by a stage driver(not shown) and is moved along a Y-axis direction. After the substrate 20 having the EL display devices 10 formed thereon is disposed on the stage 30, the stage 30 is sequentially moved along the Y-axis direction in order to mark the information barcode by using the ink-jet marker 40 on the EL display devices 10 arranged on row and column basis on the substrate 20. More specifically, after the information barcode is marked on all of the EL display devices 10 arranged in one row in the substrate 20, the stage 30 is moved along the Y-axis direction in order to mark the information barcode on the other EL display device 10 arranged in the next row.

[0039] The ink-jet marker 40 functions to mark the information barcode for the EL display device by using an ink-jet system on the packaging plate 90 of the EL display devices. The information barcode for the EL display devices 10 includes a various of information on a date representing the time when the EL display device 10 is made, a property of the EL display device 10 and the like. At this time, the information barcode for the EL display devices 10 has the information different from each other in order to identify the respective EL display devices 10.

[0040] Meanwhile, the ink-jet system includes a thermal system or a piezoelectric system. The piezoelectric system among these is mainly used. The ink-jet marker 40 for the piezoelectric system 50 includes a vessel 42 for containing a material to be jetted, and an ink-jet head 44 for jetting the material supplied from the vessel 42, as shown in FIG. 4. The vessel 42 is filled with the ink, and the ink-jet head 54 is provided with a piezoelectric element and a nozzle 46 for jetting the ink contained in the vessel 42. If a voltage is applied to the piezoelectric element, then a physical pressure is produced to repeatedly cause a contraction and a relaxation of a flow path between the vessel 42 and the nozzle 46. Owing to this repeated contraction and relaxation, the ink is jet through the nozzle 46. The ink-jet marker 40 jets the ink to the EL display devices 10 while being moved by the ink-jet driver 50 along a X-axis direction to thereby mark the information barcode for the EL display devices 10. Herein, the ink-jet marker 40 is controlled by a system(not shown) to mark a desired information to each of the EL display devices 10.

[0041] A marking method using a barcode marking device for the EL display device will be described as follows in detail. First of all, the substrate 20 having the EL display devices 10 is disposed on the stage 30. The EL display devices 10 arranged in a first column is located at a place in which the ink-jet marker 40 is located by moving the stage 30 along the Y-axis direction. Then, the desired information barcode is marked on each of the EL display devices 10 by the ink-jet marker 10 moving from a first location 40a to a second location 40b along the X-axis direction by the ink-jet driver 50. Herein, the first location 40a corresponds to a location of a first EL display device 10 arranged in one row on the substrate 20 having the EL display devices 10. The second location 40b corresponds to a location of a last EL display device 10 arranged in the row on the substrate 20. When the information barcode is marked on all of the EL display devices 10 arranged in the first row, the ink-jet marker 40 located in the second location 40b is moved again to the first location 40a. And then, the stage 30 is moved along the Y-axis direction on one column basis so that the EL display devices 10 arranged in a subsequent row is located at a place in which the ink-jet marker 40 is located. Then, the information barcode is marked on each of the EL display devices 10 by the ink-jet marker 40 moving from the first location 40a to the second location 40b along the X-axis direction by the ink-jet driver 50. In this way, the above operation is repeated until the information barcode is marked on all of the EL display devices 10 arranged in a last row.

[0042] Alternatively, the present invention is made to mark two information barcodes having same information on the packaging plate 90 of the EL display device provided for a badness of the information barcode marked on the EL display device 10. In other words, as shown in FIGS. 5A and 5B, the two information barcodes includes a two-dimension (2D) barcode 100a and a text barcode 100b. The two-dimension (2D) barcode 100a and the text barcode 100b are marked on the packaging plate 90 of the EL display device by the ink-jet system in accordance with the present invention.

[0043] As described above, the information on the EL devices is stored by the two-dimension (2D) barcode 100a and the text barcode 100b when the information barcode for the EL display device is marked by the barcode marking

device for the EL display device according to the present invention. Therefore, it is easy to manage the EL display devices. Also, when a marking badness is occurred, the marking badness can be removed by using a solvent. Thus, it has an advantage that a repair is possible. Such an ink-jet method has an advantage that the time required to mark the information barcode is saved as compared with the method directly sticking the sticker through the use of the manual labor by a worker or the method etching the substrate by using the laser to mark the information barcode. Thus, it is profitable in a production yield.

[0044] As describe above, according to the barcode marking method and apparatus of the electro-luminescence display device of the present invention, the information barcode of the EL display device is marked through using the ink, to thereby remove the marking badness when the marking badness is occurred. As a result, a repair is possible, as well as, the time required to mark the information barcode is saved. Thus, it is possible to improve a production yield thereof.

[0045] Although the present invention has been explained by the embodiments shown in the drawings described above, it should be understood to the ordinary skilled person in the art that the invention is not limited to the embodiments, but rather that various changes or modifications thereof are possible without departing from the spirit of the invention. Accordingly, the scope of the invention shall be determined only by the appended claims and their equivalents.

What is claimed is:

1. A barcode marking method for an electro-luminescence display device, using an ink-jet head and a stage which are installed movable respectively, comprising:

disposing a substrate having a plurality of electro-luminescence display devices on the stage; and

marking an information barcode on the electro-luminescence display devices by using the ink jetted from the ink-jet head while moving at least any one of the stage and the ink-jet head.

2. The barcode marking method according to claim 1, wherein the stage is moved along any one of X-axis direction and Y-axis direction.

3. The barcode marking method according to claim 2, wherein the ink-jet head is moved along any one of X-axis direction and Y-axis direction, which are crossed from a moving direction of the stage.

4. The barcode marking method according to claim 1, wherein the information barcode includes:

a date information representing the time when the electro-luminescence display device is made; and

a property information representing the property of each the electro-luminescence display device.

5. The barcode marking method according to claim 1, wherein, the information barcode includes:

a first barcode; and

a second barcode different shape from the first barcode.

6. The barcode marking method according to claim 5, wherein, the first barcode includes a two-dimension (2D) letter shape, and

the second barcode includes a text.

7. The barcode marking method according to claim 5, wherein, the first and the second barcodes are marked together with on the same electro-luminescence display device.

8. The barcode marking method according to claim 7, wherein, each electro-luminescence display device includes an organic light-emitting layer and a packaging plate for encapsulating the organic light-emitting layer, and the first and the second barcodes are marked on the packaging plate.

9. A barcode marking apparatus for an electro-luminescence display device, comprising:

an ink-jet head which is installed to be movable and can jet the ink; and

a stage, installed to be movable toward a moving direction crossing a moving direction of the ink-jet head, for disposing a substrate having a plurality of electro-luminescence display devices thereon,

wherein an information barcode is marked on the electro-luminescence display devices by using the ink jetted from the ink-jet head while moving at least any one of the stage and the ink-jet head.

10. The barcode marking apparatus according to claim 9, wherein the stage is moved along any one of X-axis direction and Y-axis direction.

11. The barcode marking method according to claim 10, wherein the ink-jet head is moved along any one of X-axis direction and Y-axis direction, which are crossed from a moving direction of the stage.

12. The barcode marking apparatus according to claim 9, wherein the information barcode includes:

a date information representing the time when the electro-luminescence display device is made; and

a property information representing the property of each the electro-luminescence display device.

13. The barcode marking apparatus according to claim 9, wherein, the information barcode includes:

a first barcode; and

a second barcode different shape from the first barcode.

14. The barcode marking apparatus according to claim 13, wherein, the first barcode includes a of a two-dimension (2D) letter shape, and

the second barcode includes a text.

15. The barcode marking apparatus according to claim 13, wherein, the first and the second barcodes are marked together on the same electro-luminescence display device.

16. The barcode marking apparatus according to claim 15, wherein, each electro-luminescence display device includes an organic light-emitting layer and a packaging plate for encapsulating the organic light-emitting layer, and the first and the second barcodes are marked on the packaging plate.

17. A barcode marking apparatus for an electro-luminescence display device, comprising:

a stage, installed to be movable toward a Y-axis direction, for being disposed a mother glass in which a column of a plurality of electro-luminescence display devices is formed along a X-axis direction and a row of a plurality of electro-luminescence display device is formed along the Y-axis direction; and

an ink-jet head, installed to be movable toward the X-axis direction and jetting the ink, for marking together with at least two or more information on each the electro-luminescence display device.

18. The barcode marking apparatus according to claim 17, wherein the information barcode includes:

a date information representing the time when the electro-luminescence display device is made; and

a property information representing the property of each the electro-luminescence display device.

19. The barcode marking apparatus according to claim 17, wherein at least the two or more information are marked in a text shape together with a two-dimension (2D) letter shape on each the electro-luminescence display device.

20. The barcode marking apparatus according to claim 17, wherein each the electro-luminescence display device includes an organic light-emitting layer and a packaging plate for encapsulating the organic light-emitting layer; and

at least the two or more information are marked on the packaging plate.

* * * * *

专利名称(译)	用于电致发光显示装置的条形码标记方法和装置		
公开(公告)号	US20050078164A1	公开(公告)日	2005-04-14
申请号	US10/960968	申请日	2004-10-12
申请(专利权)人(译)	LG电子INC.		
当前申请(专利权)人(译)	LG电子株式会社.		
[标]发明人	KWON SEUNG HO TAK YOON HEUNG		
发明人	KWON, SEUNG HO TAK, YOON HEUNG		
IPC分类号	H05B33/10 B41J3/01 B41J3/28 B41J3/407 H01L51/50 B41J2/01		
CPC分类号	B41J3/01 B41J3/407 B41J3/28		
优先权	1020030071075 2003-10-13 KR		
其他公开文献	US7311396		
外部链接	Espacenet USPTO		

摘要(译)

本发明涉及一种用于电致发光显示装置的条形码标记方法和装置。根据本发明的电致发光显示装置的条形码标记方法和装置，包括在电致发光显示装置上使用从喷头喷射的墨水在至少移动任何一个的同时标记信息条形码。舞台和喷头。

